

Hydraulic system with electromechanical integration

1、Brief introduction

INI HYDRAULIC CO;LTD could provide products including hydraulic system, electromatic control system, integrated hydraulic valve blocks, hydraulic test-bed manufacturing and local debugging for customers. The company employed many senior professional talents with rich experience in hydraulic,machinery,

electrical and electronic.The company has advanced management mode,various kinds of advanced manufacturing mechines and inspection equipments.It supplied good products and satisfied service to the customer at home and abroad by hi-tech design, professional manufacturing and excellent management directed to market. These patent products are widely used in ships,engineering machinery, construction machinery metallurgy, light industry machinery and environment.

2、Main achievements

No	Project	Customer	Application
1	120 M ³ /h bucket wheel dredger	SHANDONG JINING navigational business bureau of administration	Ship
2	120 M ³ /h suction dredger	JIANGXI shipyard factory	
		ZHENJIANG navigation bureau	
		SHANDONG HAODAGNJA group	
3	350 M ³ /h bucket wheel dredger	HUNAN YIYANG shipyard factory	
		NANTONG TIANDAING company	
		YUNNAN YILI river electric company	
4	350 M ³ /h suction dredger	JIANGXI navigational bureau	
		NANCHANG waterway control company	
5	400kW divided dredger	ANHUI SHENZHOU machinery factory	
6	400M ³ /h suction dredger	ZHENJIANG YANGFAN ship group	
7	1000M ³ /h chain type dredger	NANCHANG waterway control company	
8	JX750 suction dredger	ANHUI waterway control company	
9	1800 M ³ /h suction rake dredger imported from Holland (updated PLC hydraulic system)	The second engineering department of SHANGHAI waterway bureau	
10	“ Third shipping piling 1” sand piling barge	NINGBO subsidiary of the third shipping administration bureau	
11	50m soft pipe laying ship for Yangtze River	NANJING Yangtze River waterway control bureau	
12	Hydraulic system for fishery cruiser, ocean supervision boat, fire boat and boat releasing equipment	The 701 research institute of China ship heavy industry company	

13	120M ³ /h multifunctional dredger	JIANGSU water machinery factory	
14	Ditcher for ocean floor oil pipeline	TIANJING TANGGU ocean ship engineering service CO, .LTD	
15	Hydraulic system for seabed cable pipe laying	SHENGLI oil field technology development center	Ship
16	50kN, 150kN mast hoist	Exported to Vietnam Hanoi BEIHAI transport company	
17	600DWT deck machinery for cargo ship	WUHAN NANHUA ship factory	
18	Hydrographic survey boat	GUANGXI GUIJIANG shipyard factory	
19	Hoisting hydraulic system for life boat	ZHENJIANG marine auxiliary machinery works	
20	SJA935 dual roller paper making equipment	WENRUI paper making factory	Light industry
21	Hydraulic hatch hydraulic system	ZHEJIANG DONGFANG ship factory	Ship
		REQING ZHONGCHUAN ship factory	
		ZHOUSHAN LIDAO ship factory	
		RELISHI ship equipment company	
22	10T, 15T, 25T,30T,35T marine crane hydraulic system	Viet Nam	
23	16T、 18T、 25T、 35T hydraulic winch system	TIANJING JINYAN engineering machinery company	
24	JB160.16A piling machinery hydraulic system	WENZHOU ZHENZHONG construction machinery company	Architecture
25	JBM150-Z piling machinery hydraulic system	WENZHOU ZHONGGANG construction machinery company	
26	Piledriver hydraulic system	Thailand	
27	Pipe layer hydraulic system	HUABEI petroleum construction company	Construction Machinery
28	7T、 15T、 20T、 25T、 30T hydraulic winch system	England Vietnam	
29	Cutter type crusher hydraulic system	SHANDONG YANGFAN company	Environment
30	100kN Hydraulic motor testing hydraulic system	NINGBO DAGANG INI hydraulic CO.,LTD	Test-stand
31	110kW hydraulic pump testing hydraulic system		
32	Thread cartridge valve testing hydraulic system		

Hydraulic Circuit Diagram

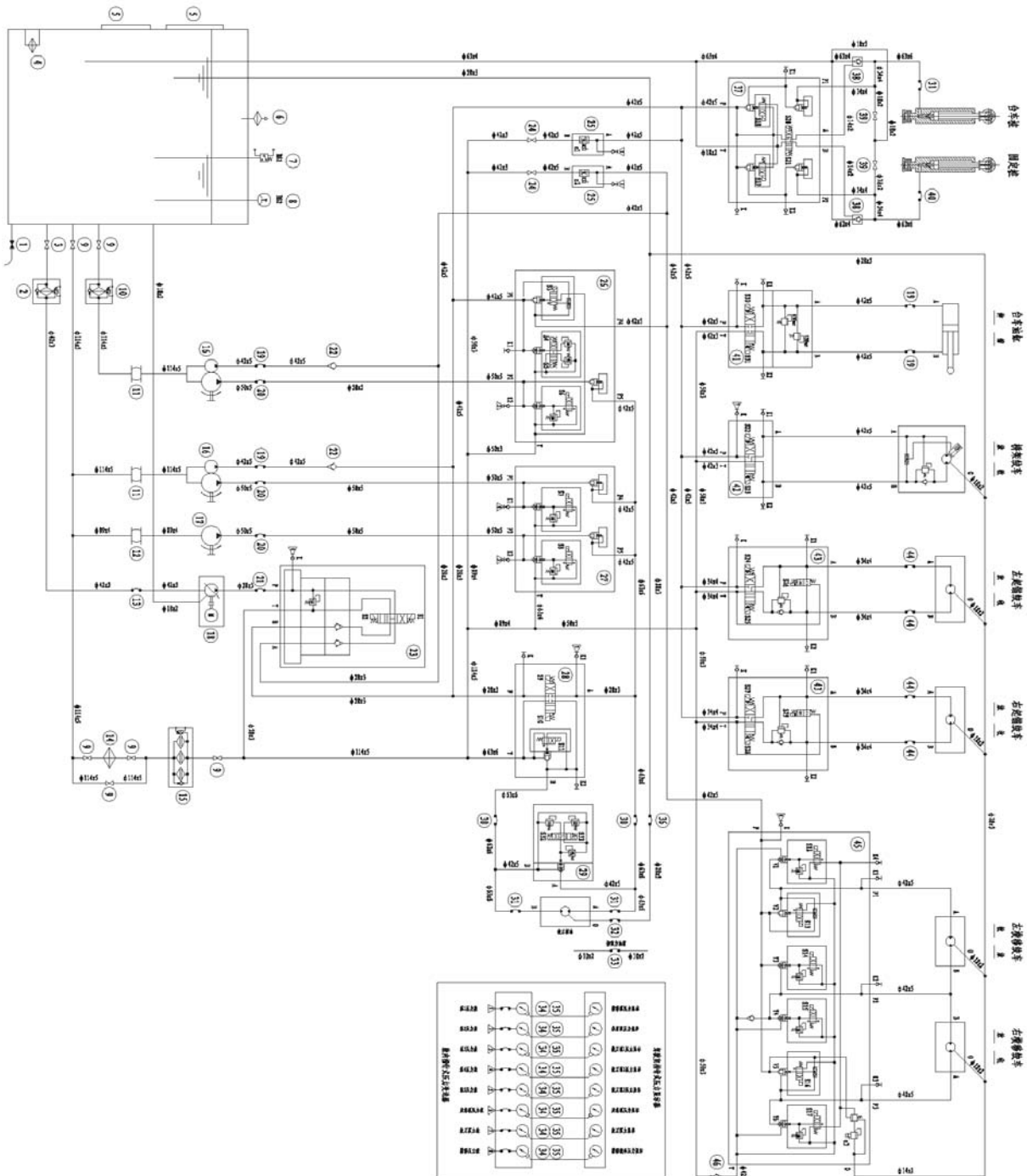

350m³/h 绞吸式挖泥船液压系统原理图
Hydraulic system diagram for
350m³/h cutter suction dredgers

Hydraulic Circuit Diagram

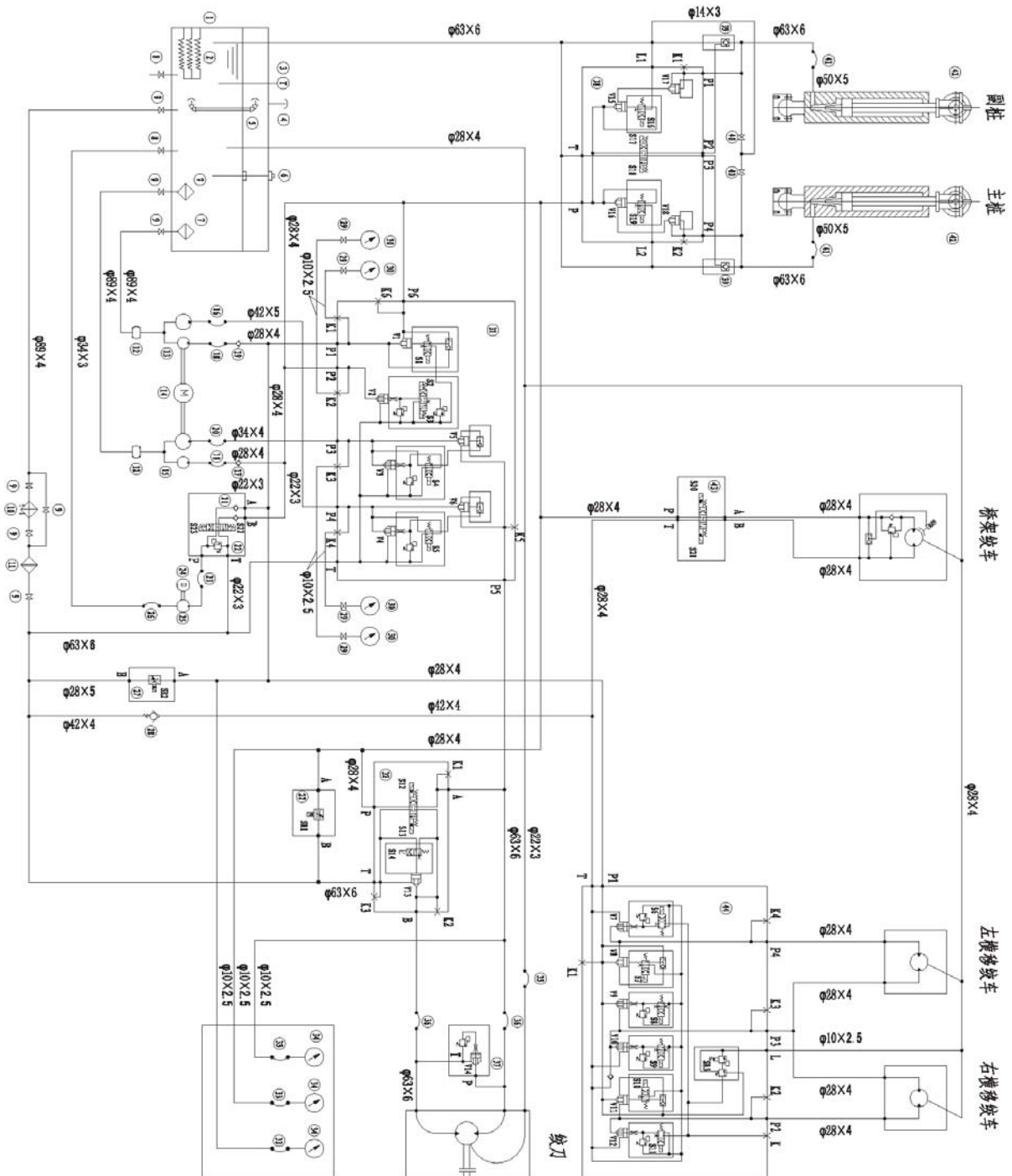

120m³/h 绞吸式挖泥船液压系统原理图

Hydraulic system diagram for
120m³/h cutter suction dredgers

Hydraulic Circuit Diagram

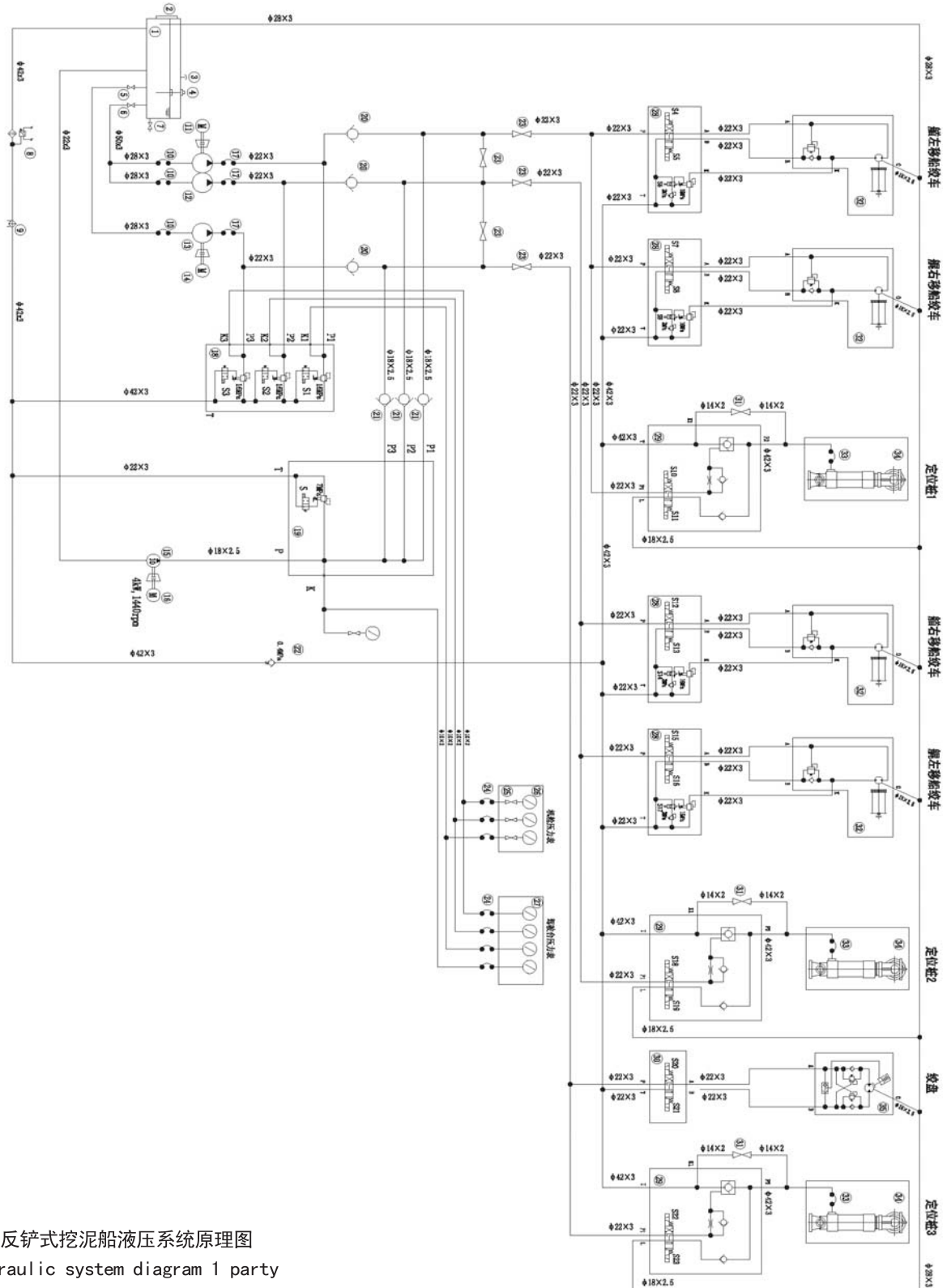

1 方反铲式挖泥船液压系统原理图
hydraulic system diagram 1 party
backhoe dredger

Hydraulic Circuit Diagram

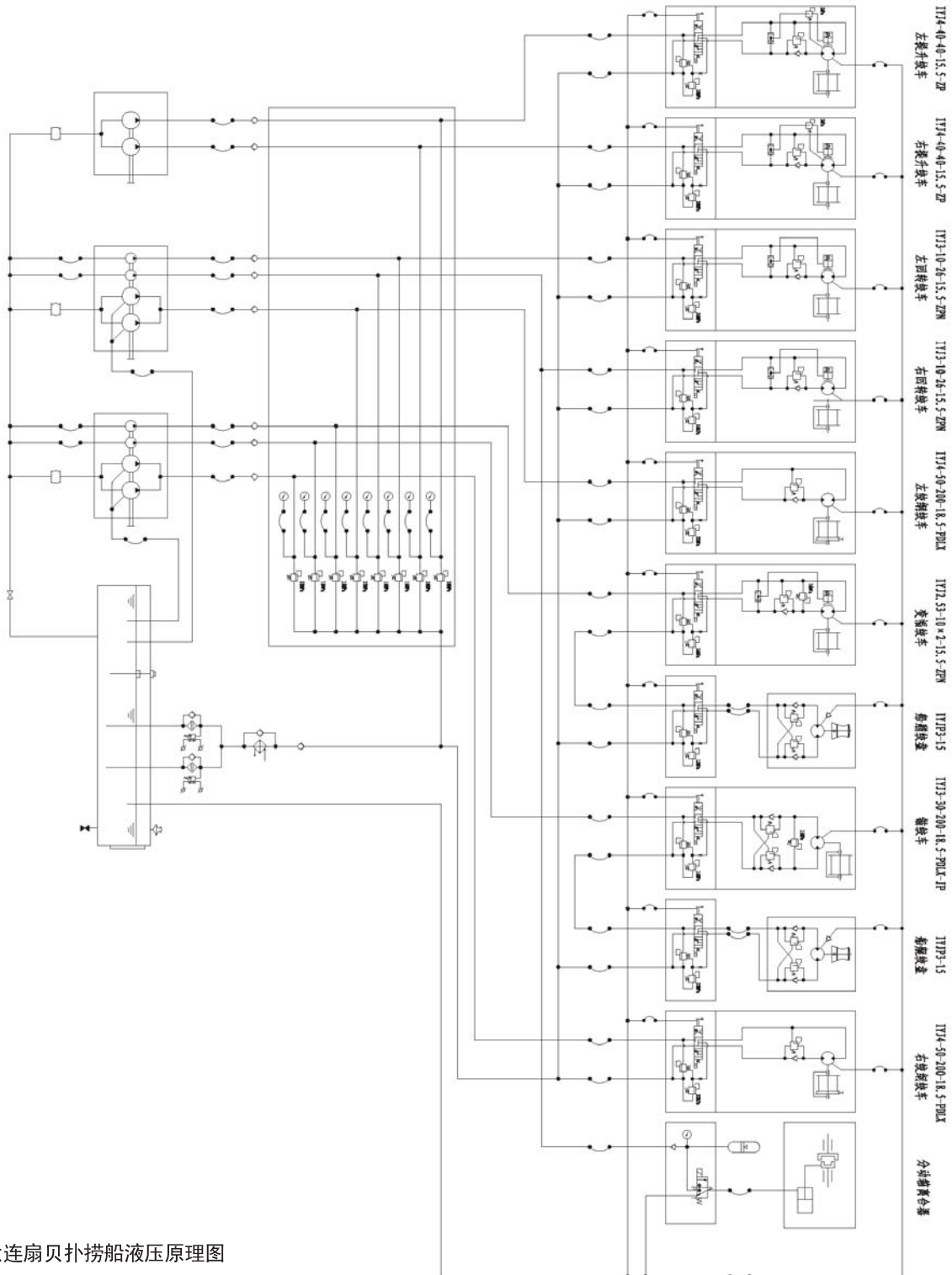

大连扇贝扑捞船液压原理图
Hydraulic system diagram for
dalian scallop-fishing ships

Hydraulic Circuit Diagram

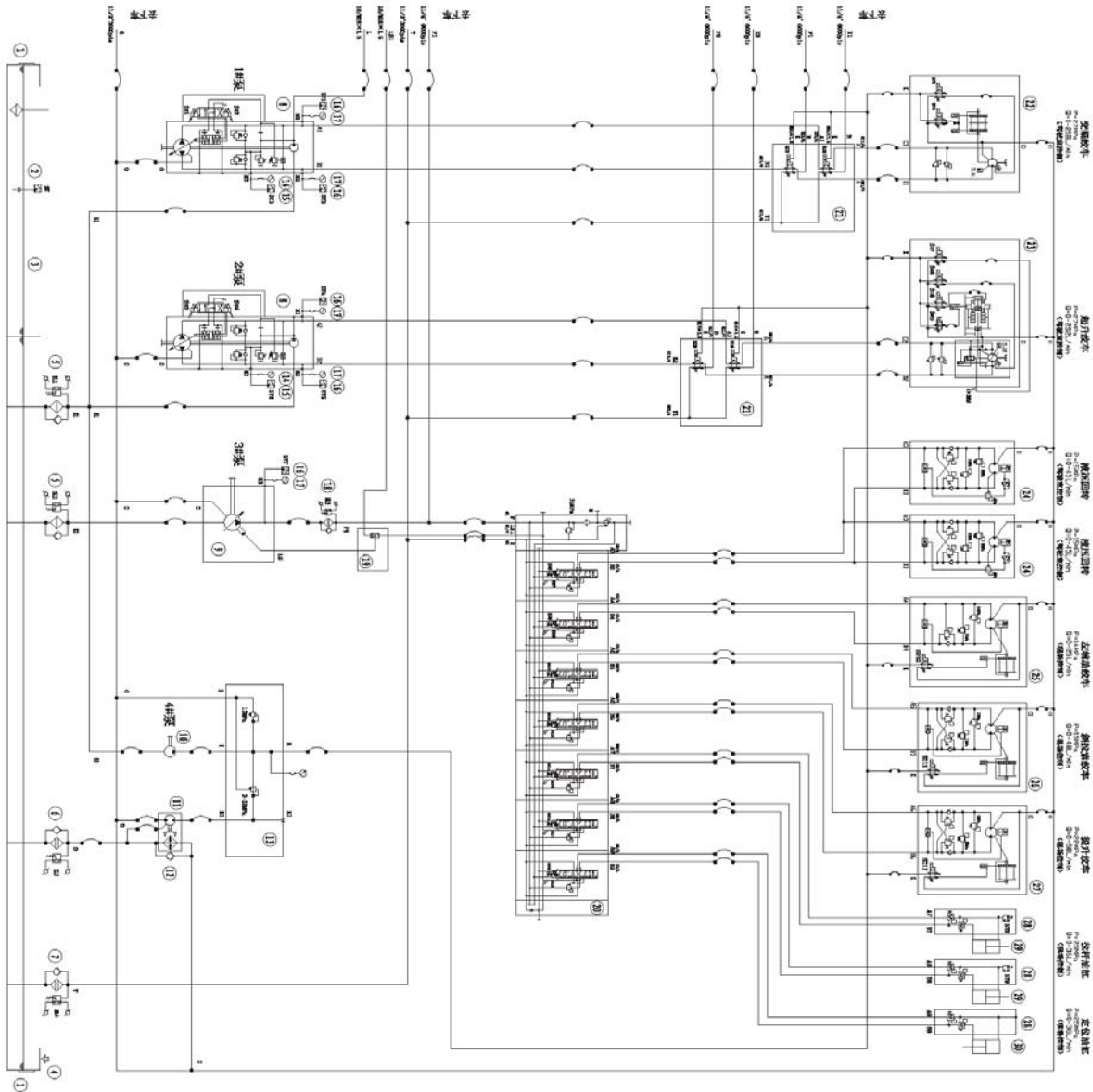

风能设备安装车液压系统原理图
Hydraulic system diagram for
wind energy equipment

Hydraulic Circuit Diagram

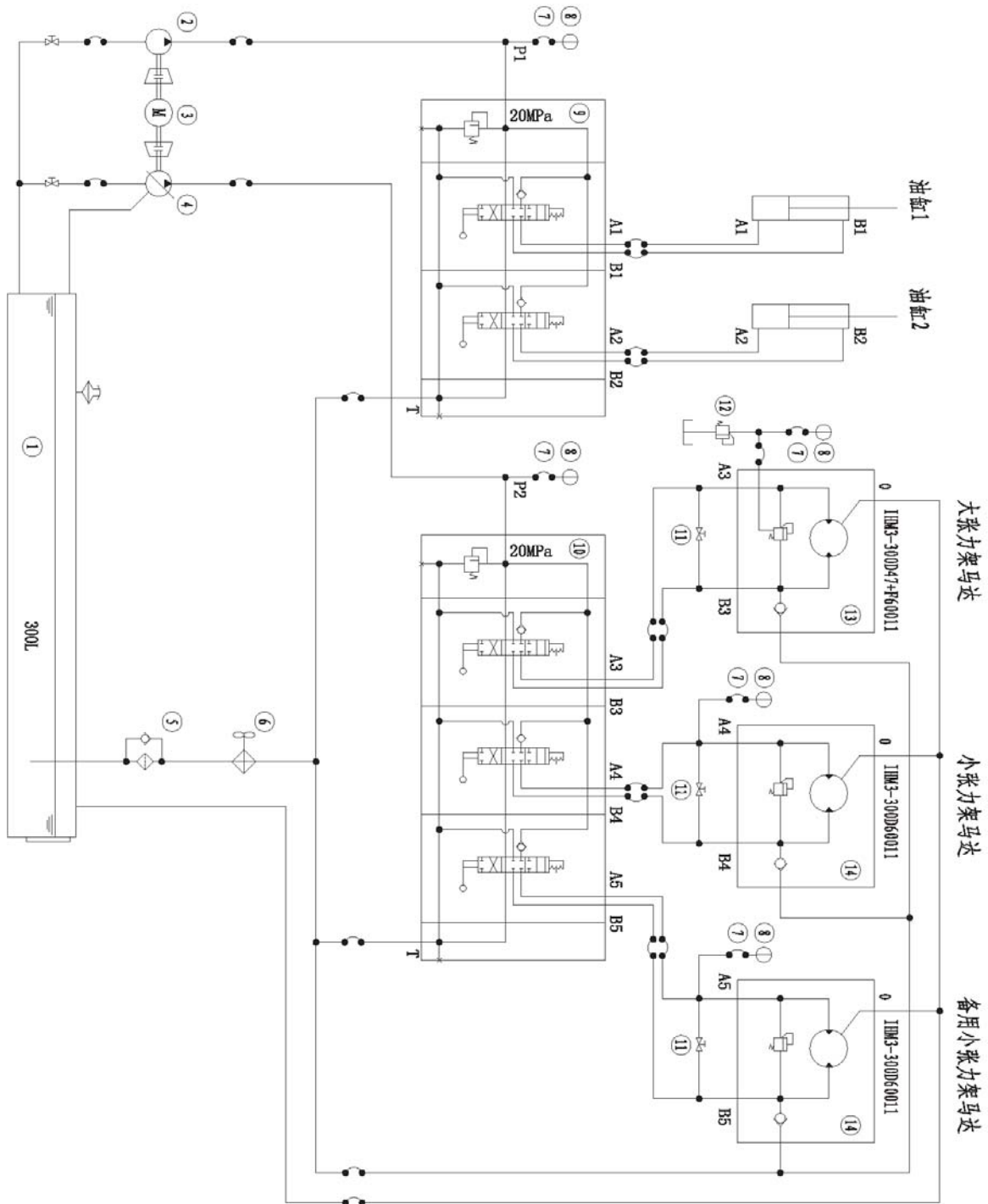

电缆车用液压系统原理图
Hydraulic system diagram for
cable vehicle

Hydraulic Circuit Diagram

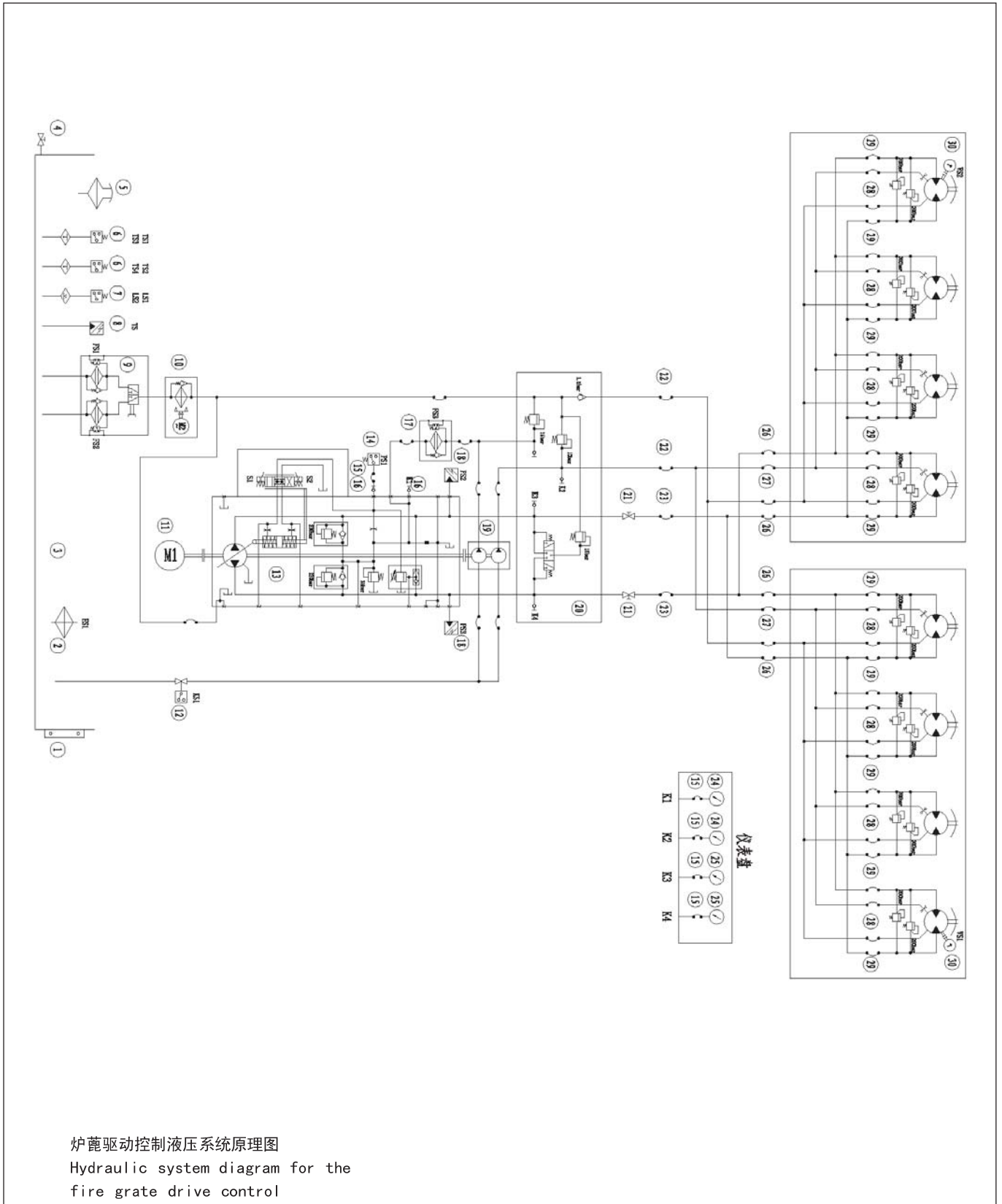

Hydraulic Circuit Diagram

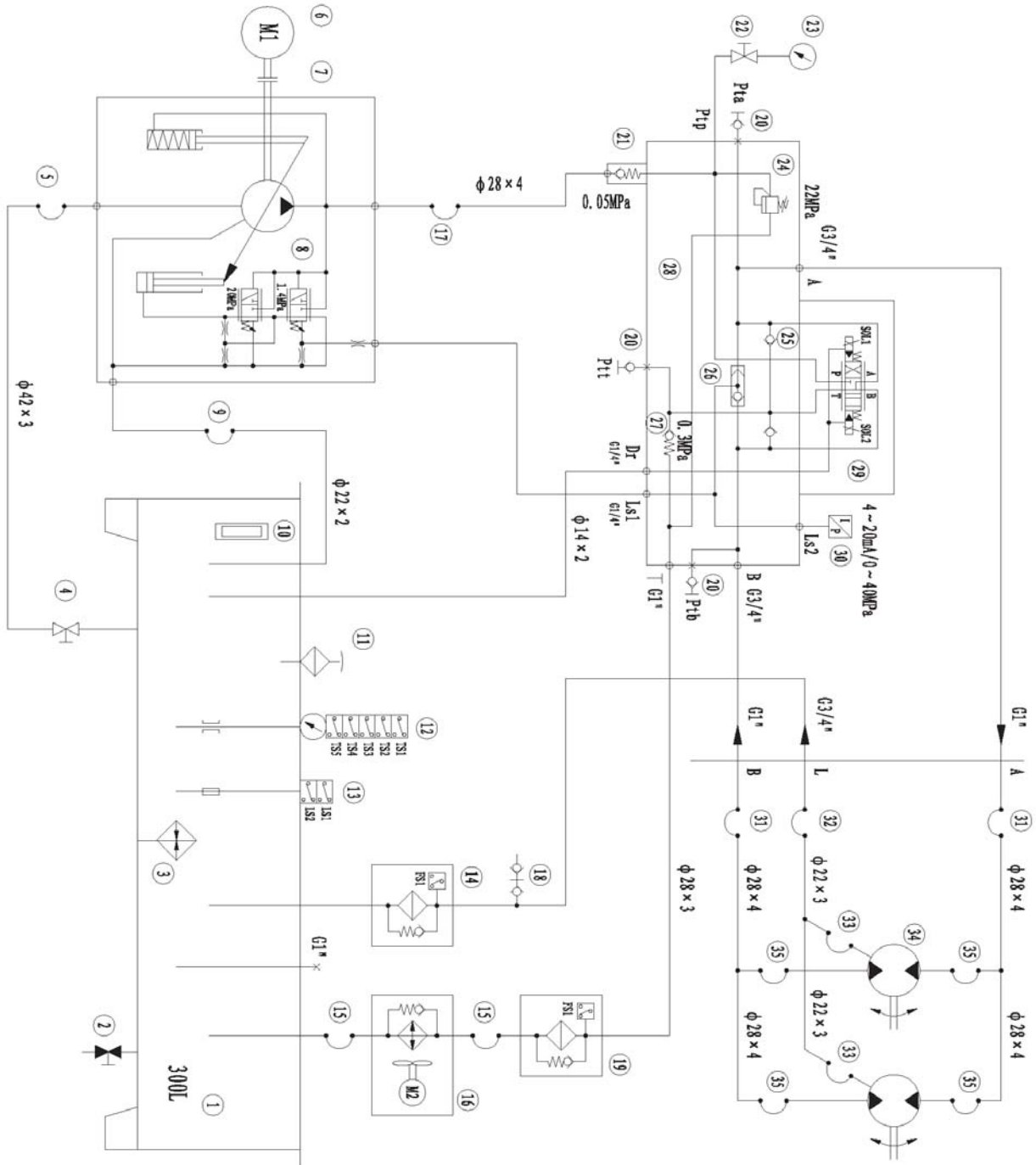

刮板式捞渣机液压系统原理图
Hydraulic system diagram for scraper slag fishing machine

Hydraulic Circuit Diagram

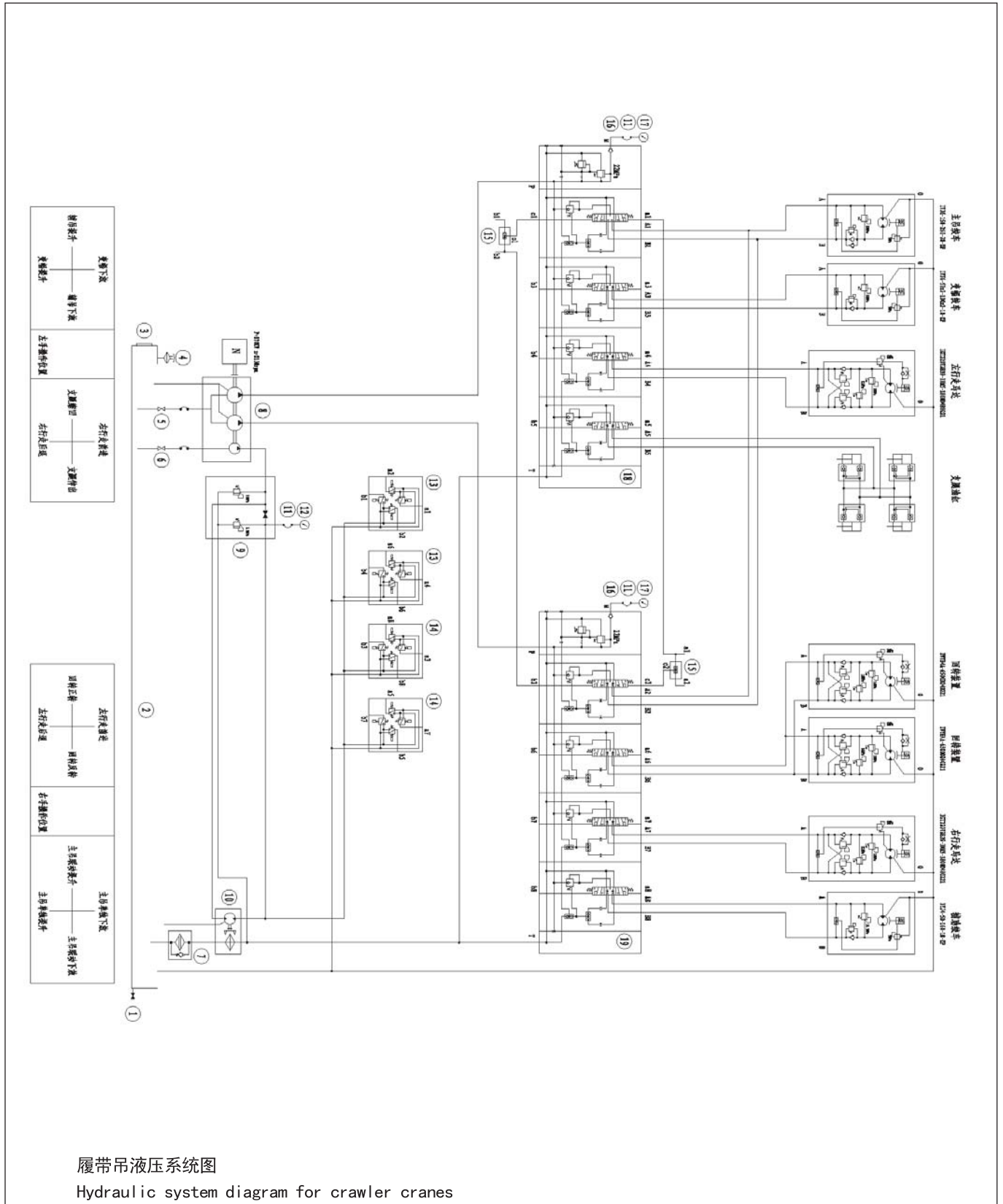

Hydraulic Circuit Diagram

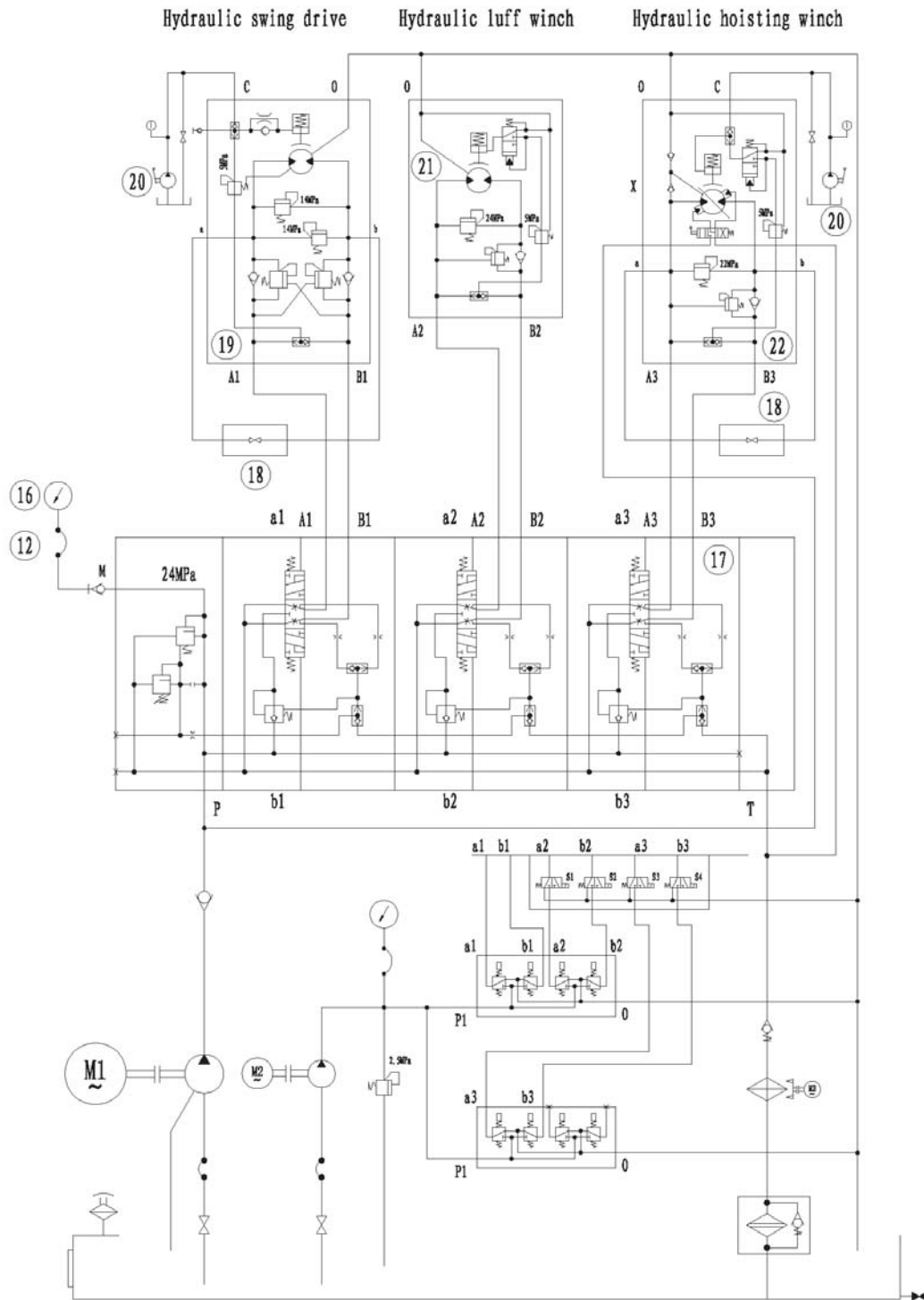

10吨船用吊车液压系统原理图

Hydraulic system diagram for 10T cutter marine crane

Hydraulic Circuit Diagram

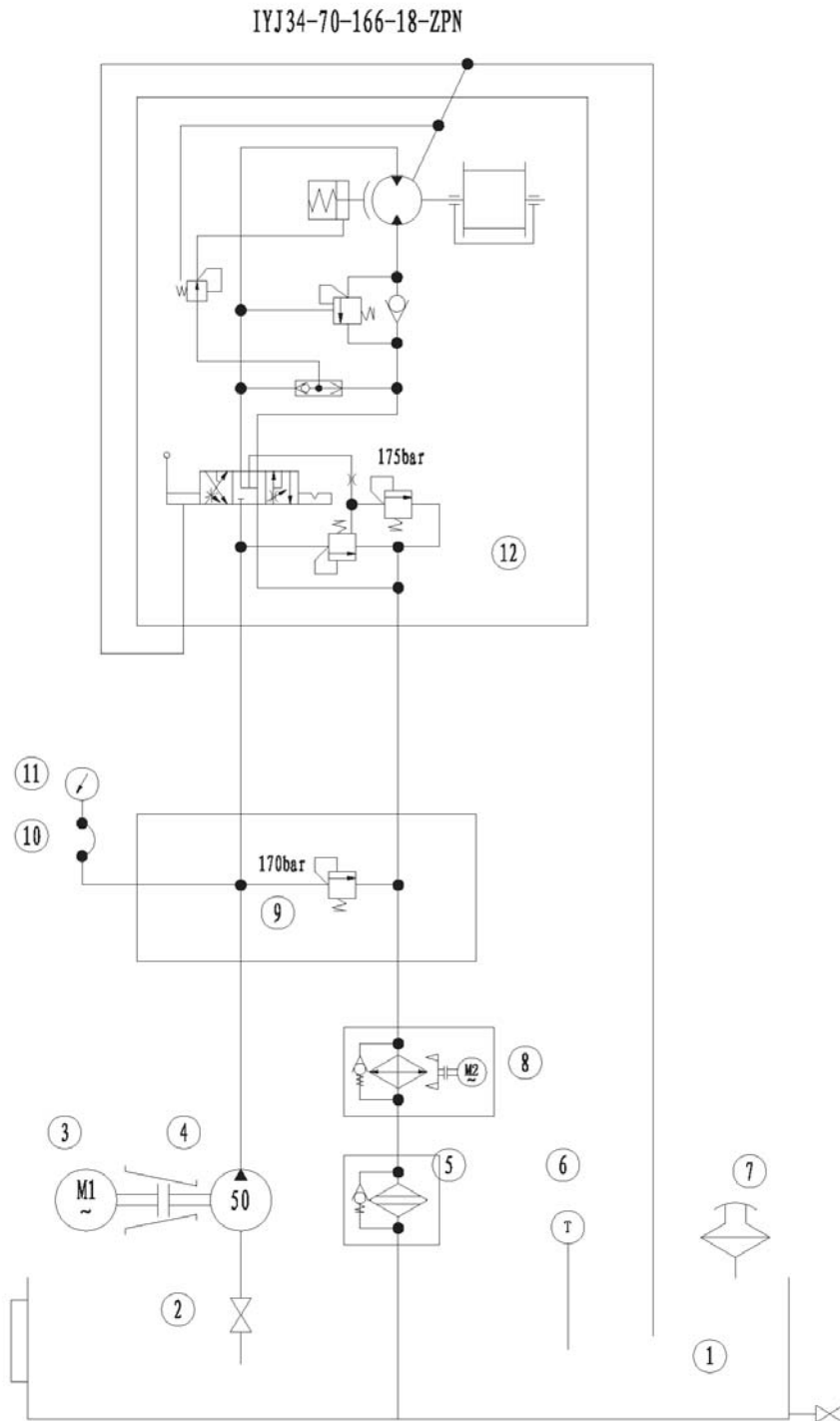

液压绞车 (IYJ34-70-166-18-ZPN) 液压原理图

IYJ34-70-166-18-ZPN Hydraulic system diagram for hydraulic winch

Hydraulic Circuit Diagram

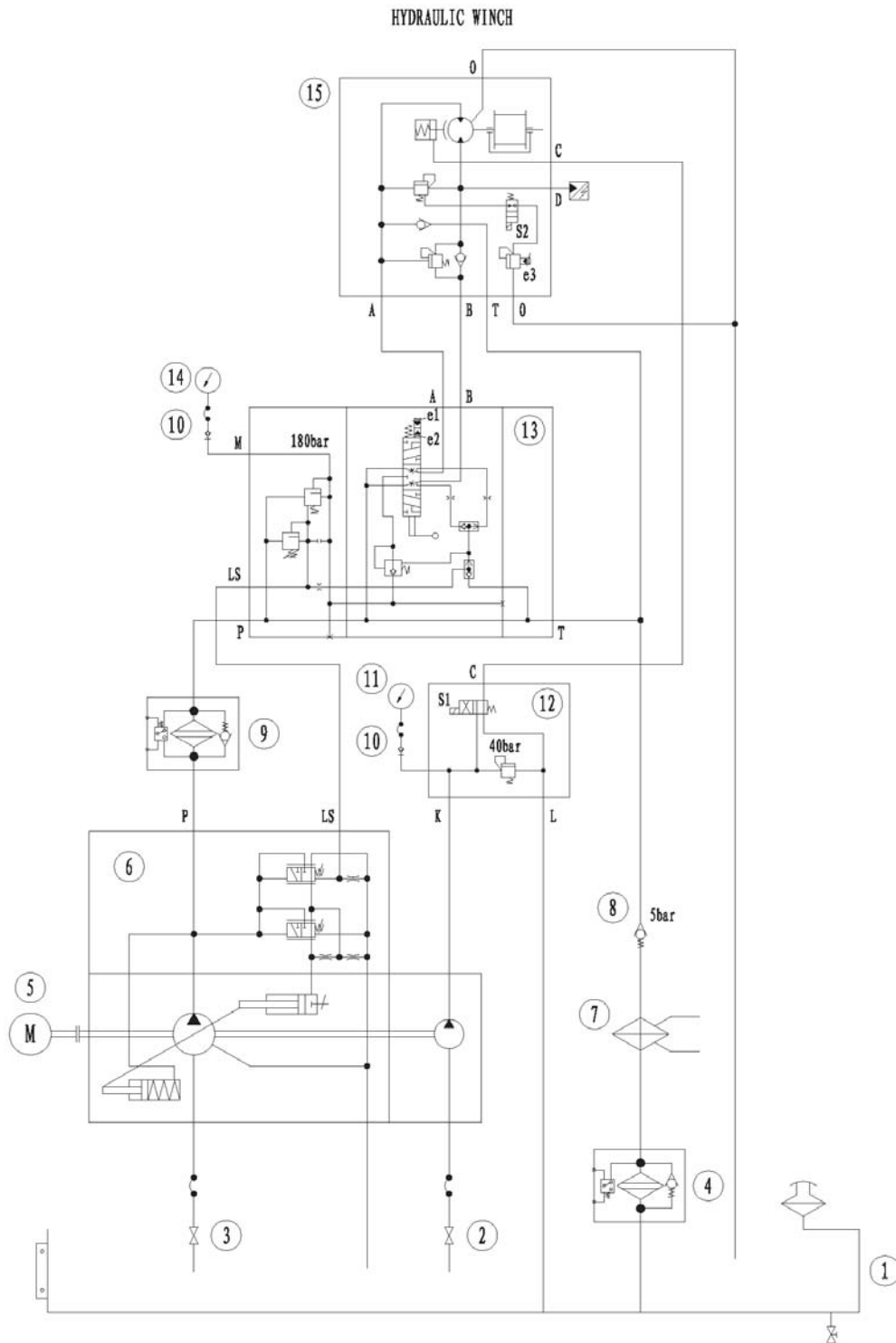

液压绞车原理图

Hydraulic system diagram for hydraulic winch

Hydraulic Circuit Diagram

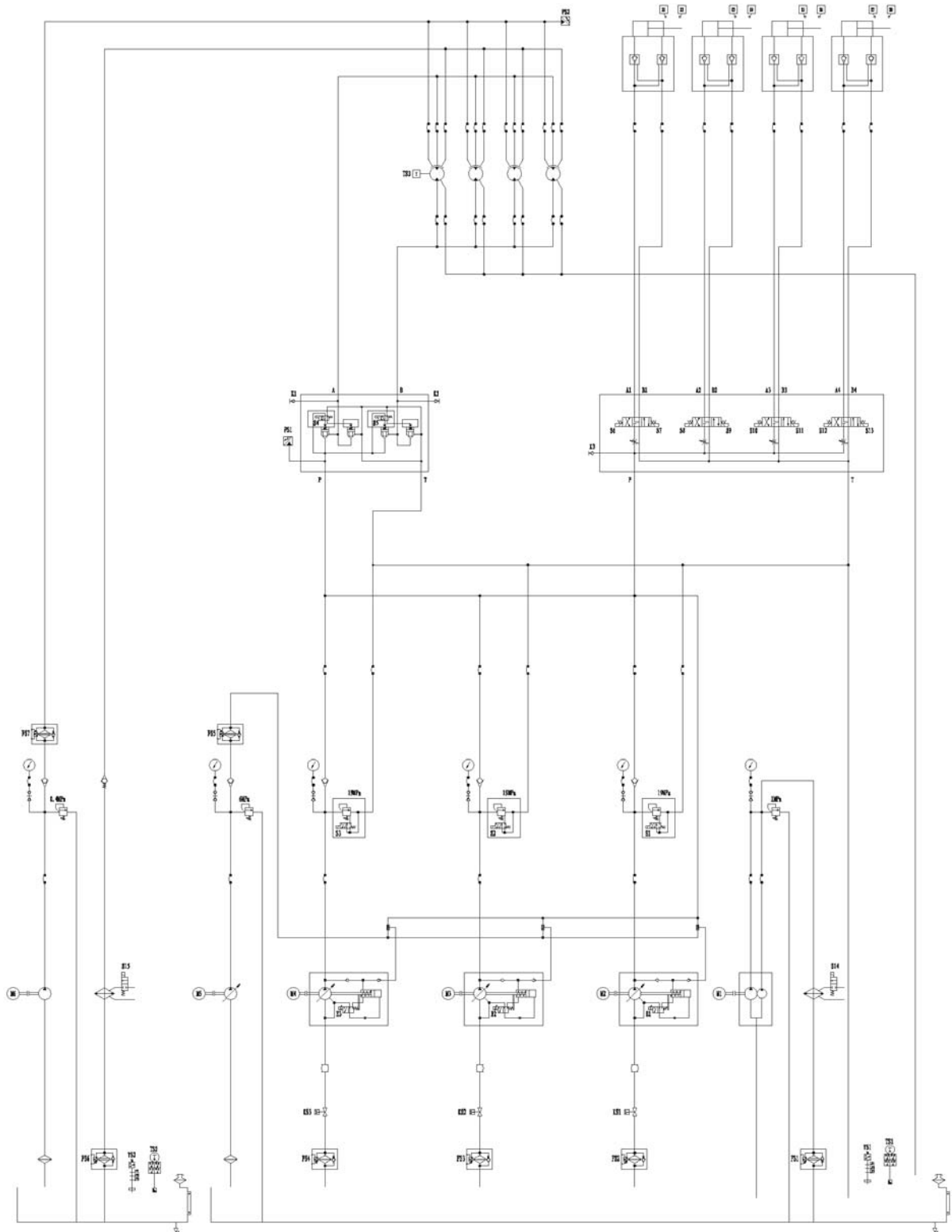

炉底回转装置驱动系统液压原理图

Hydraulic system diagram for rotary device driving system

Hydraulic Unit Figure

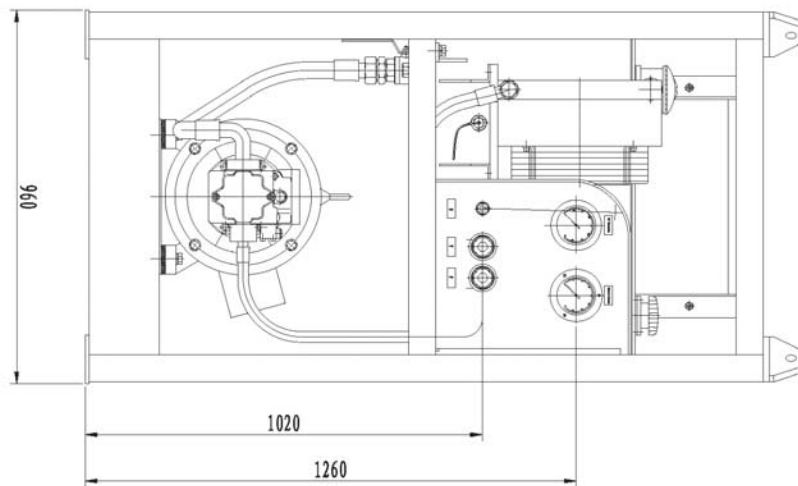
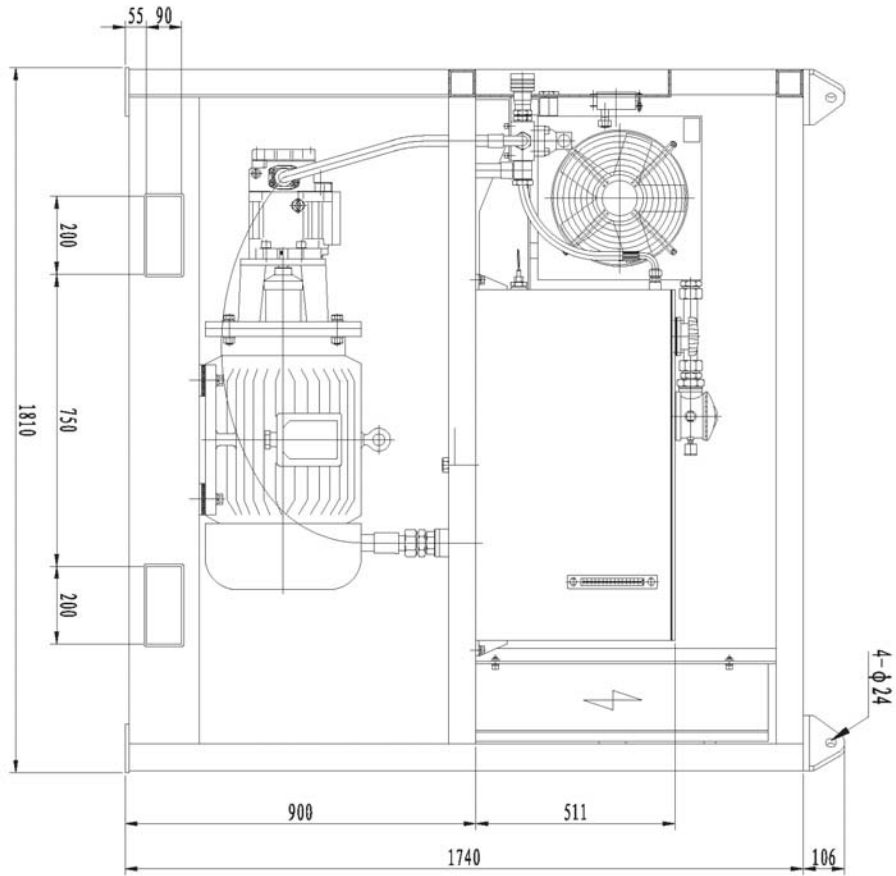

液压绞车 (IYJ4-70-500-22-ZP) 配套液压泵站
 IYJ4-70-500-22-ZP hydraulic winch power pack

Hydraulic Unit Figure

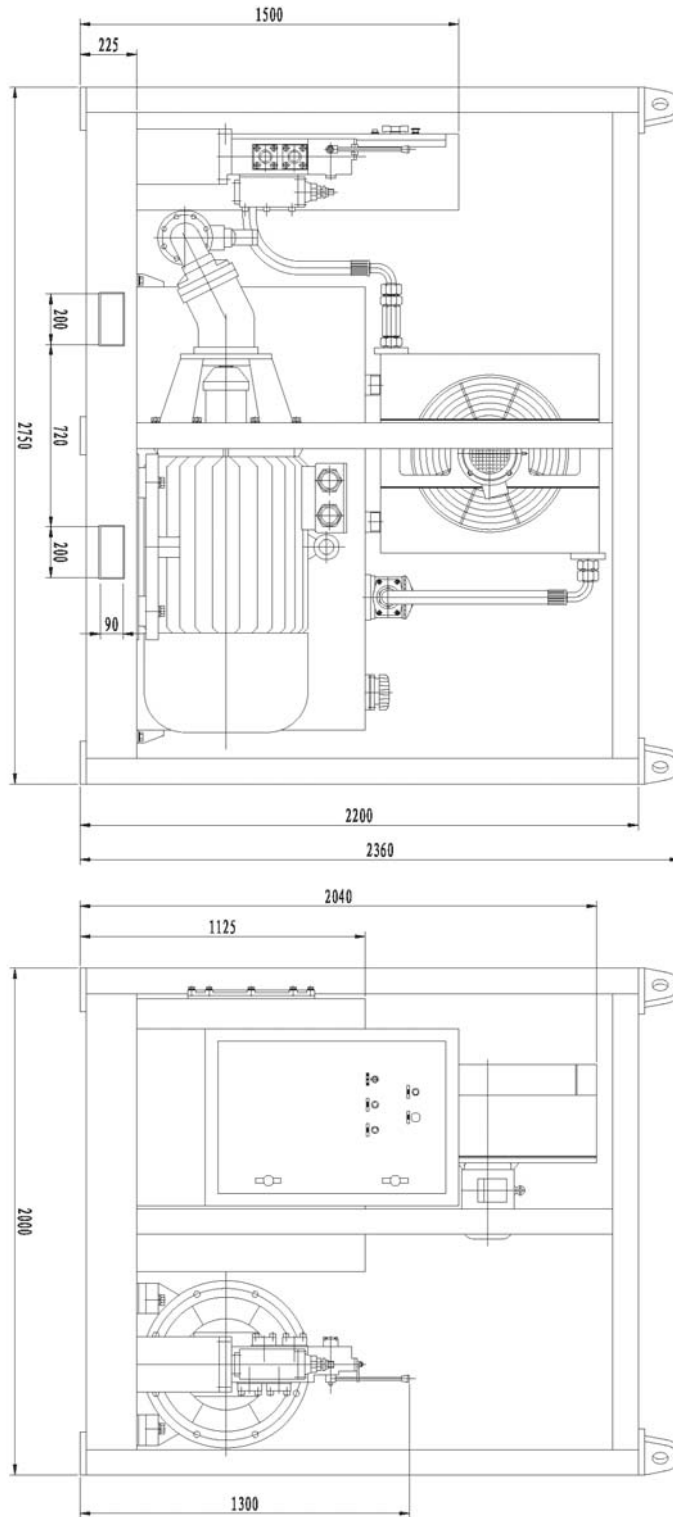

液压绞车 (IYJ466-110-3000-20.5-ZPG) 配套液压泵站
 IYJ466-110-3000-20.5-ZPG hydraulic winch power pack

Hydraulic Unit Figure

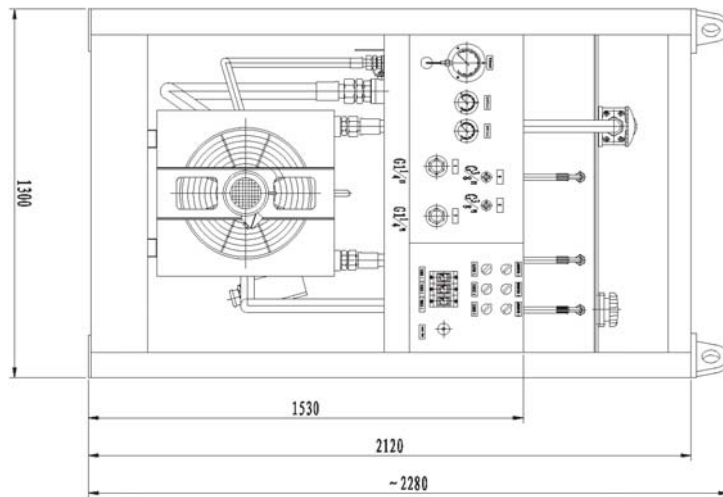
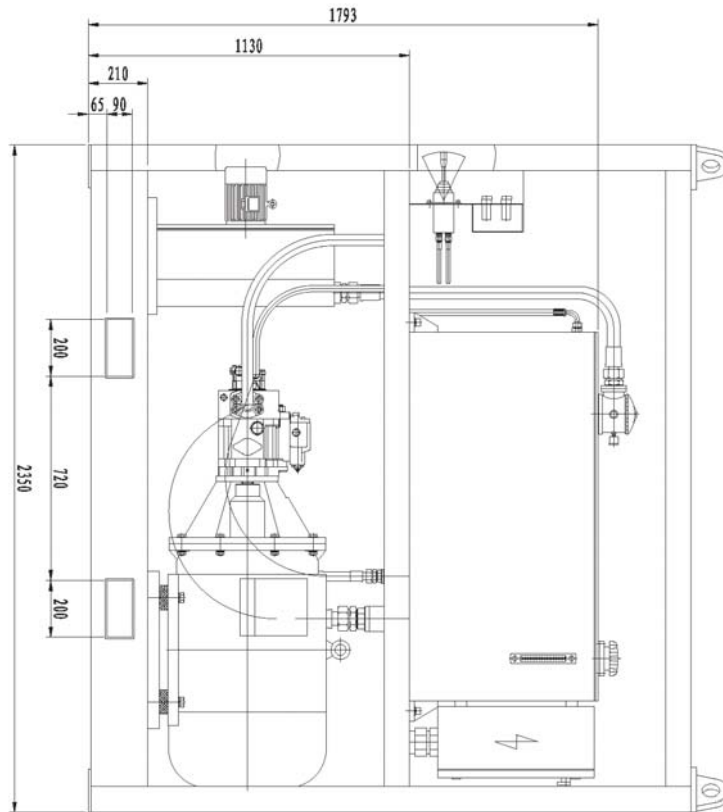

液压泵站
Hydraulic power pack

Hydraulic Unit Figure

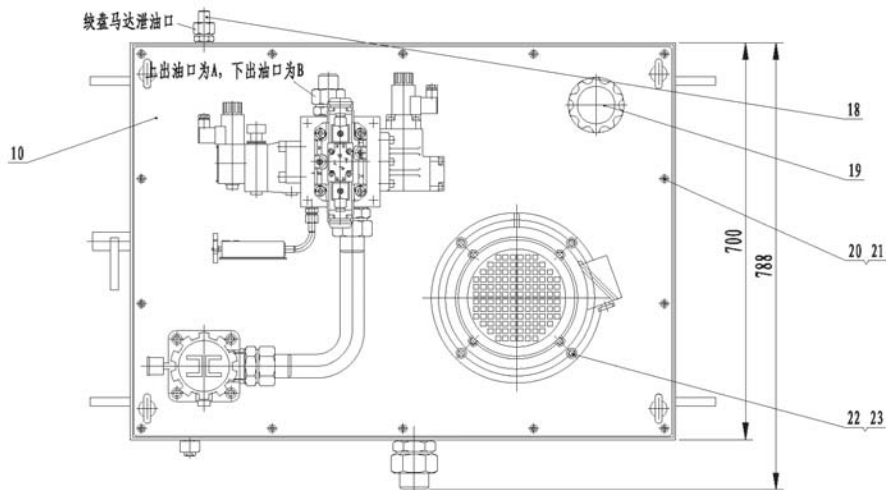
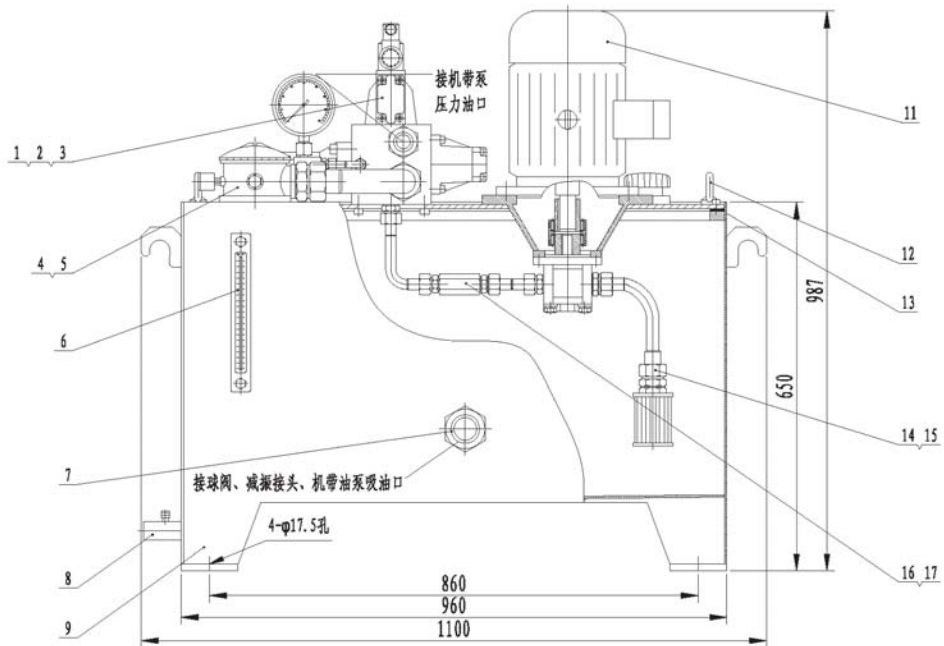

5吨绞盘液压站布置图

Power pack for 5t hydraulic capstans

Hydraulic Unit Figure

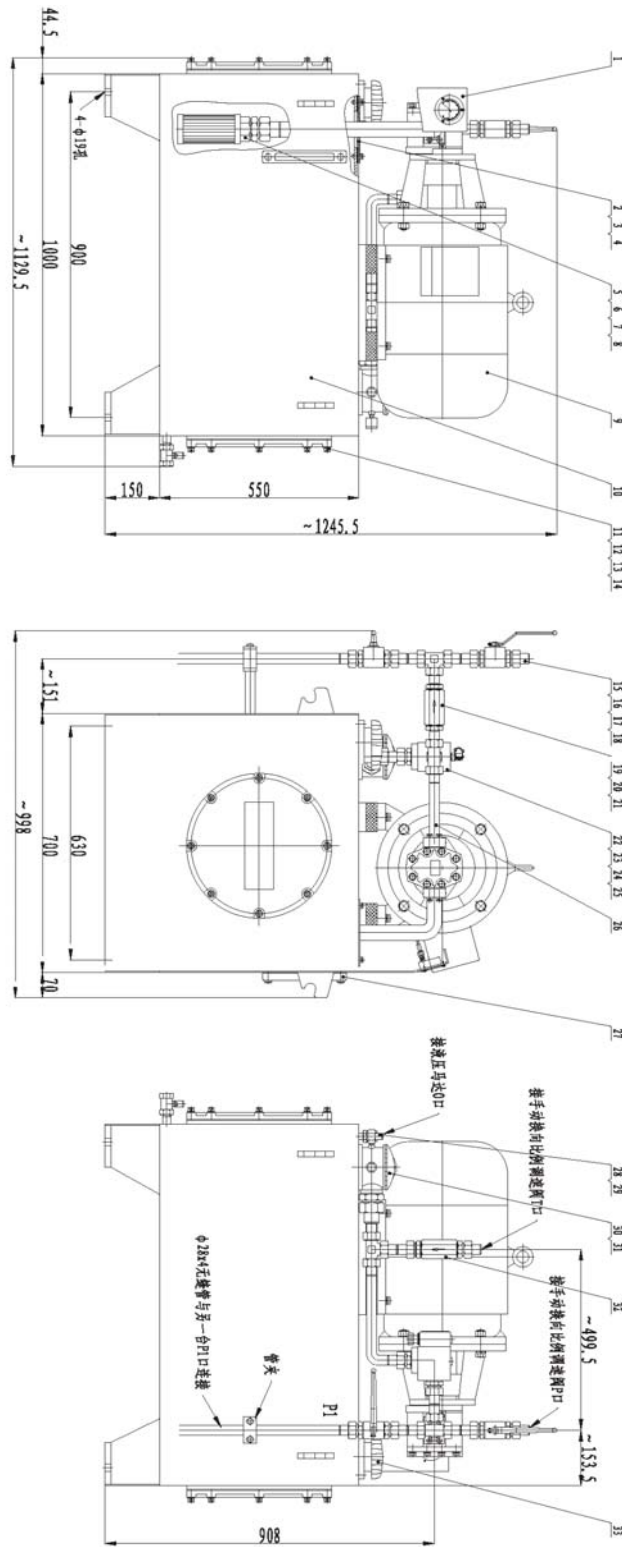

液压绞车 (IYJ2. 53-50-50-22-ZPN) 配套液压泵站

IYJ2. 53-50-50-22-ZPN power pack for hydraulic winch

Hydraulic Unit Figure

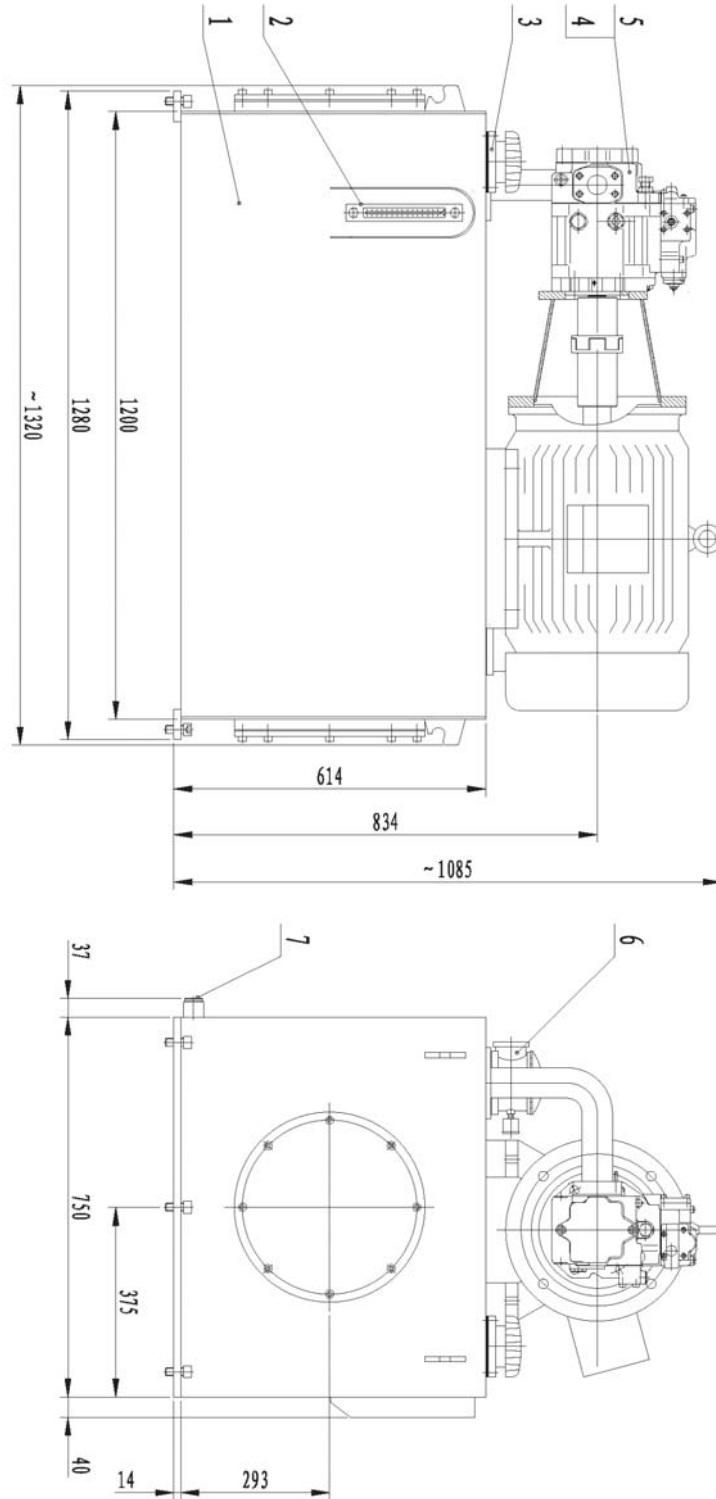

液压绞车配套系统布置图

Power pack for hydraulic winches

Hydraulic Unit Figure

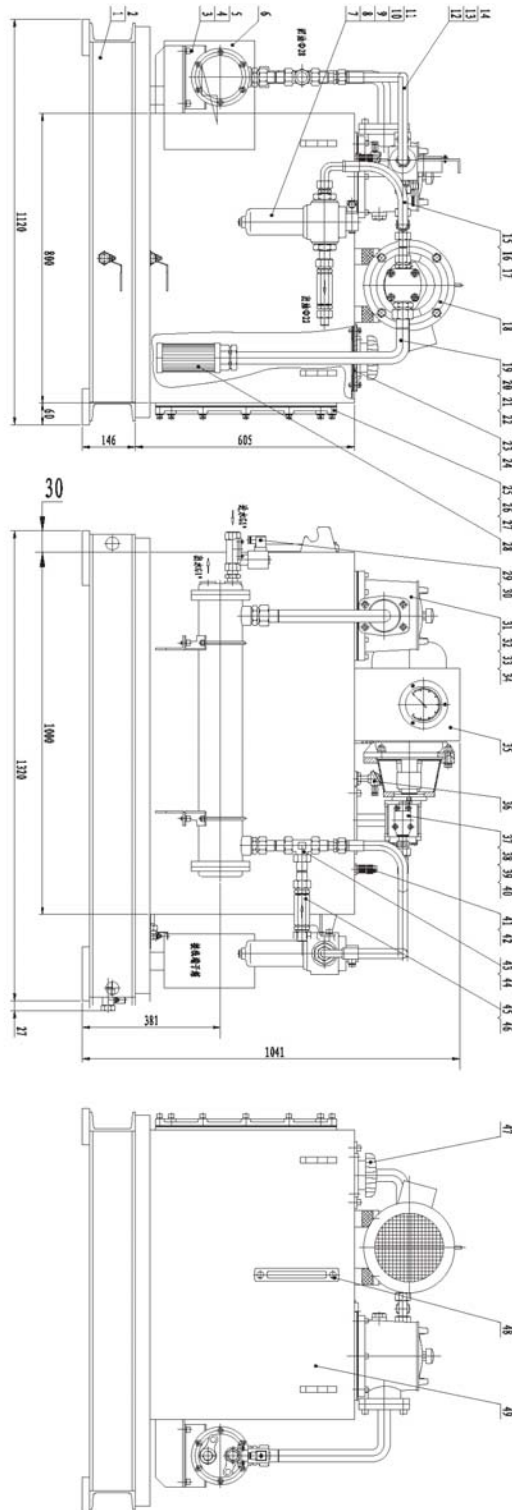

冲洗泵站
Power pack for flushing

Hydraulic Unit Figure

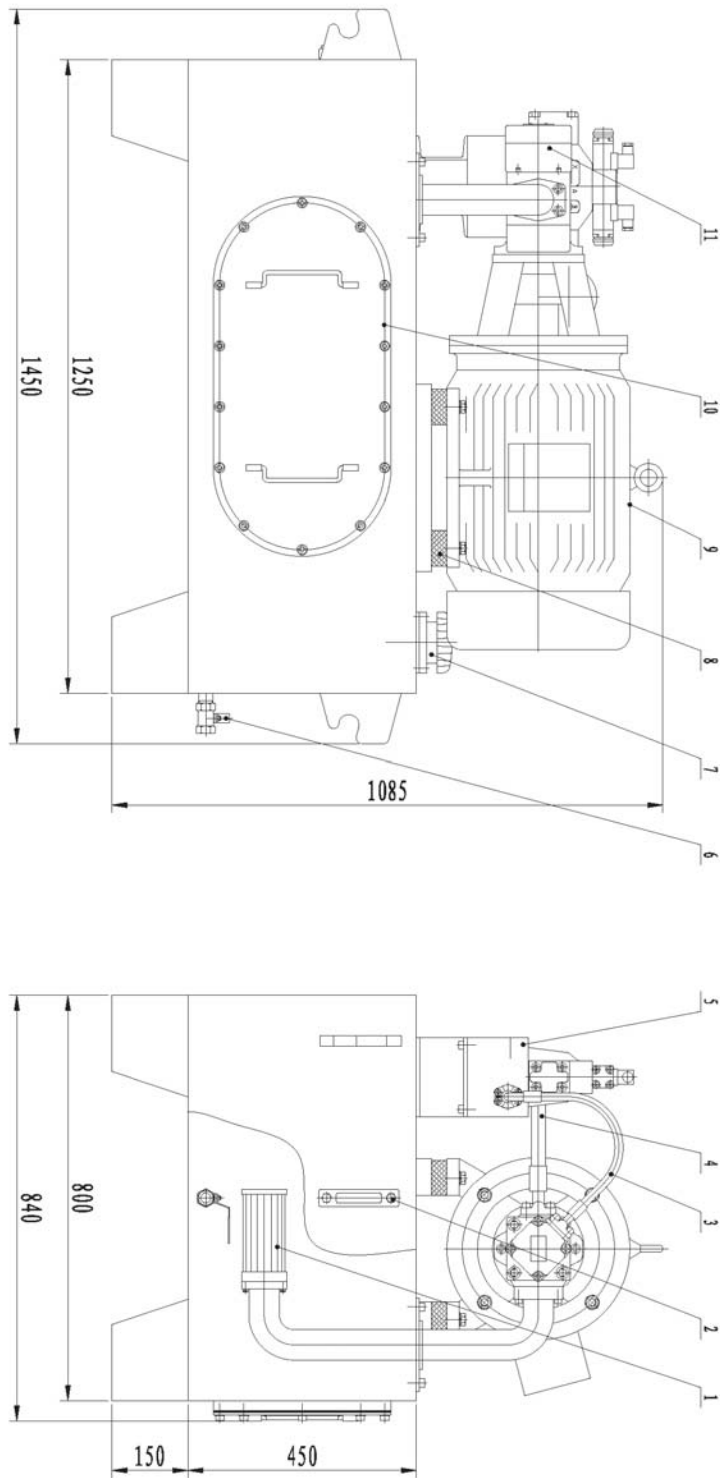

液压泵站
Hydraulic power unit

Hydraulic Unit Figure

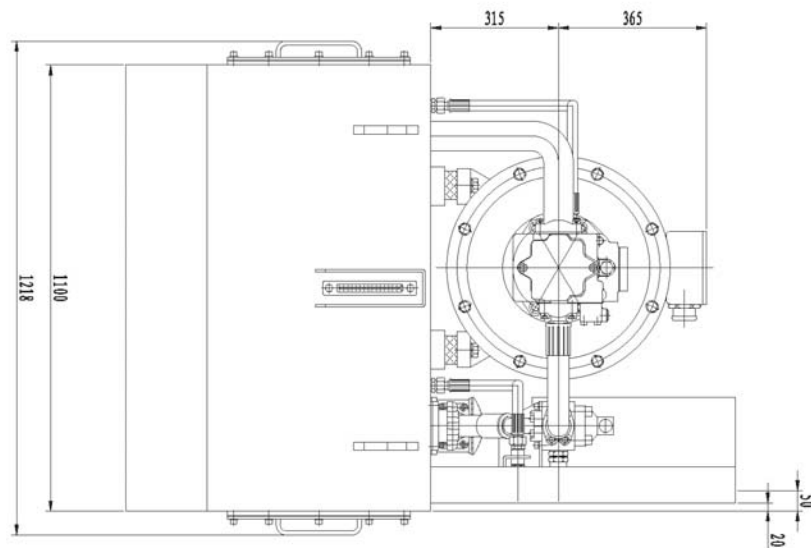
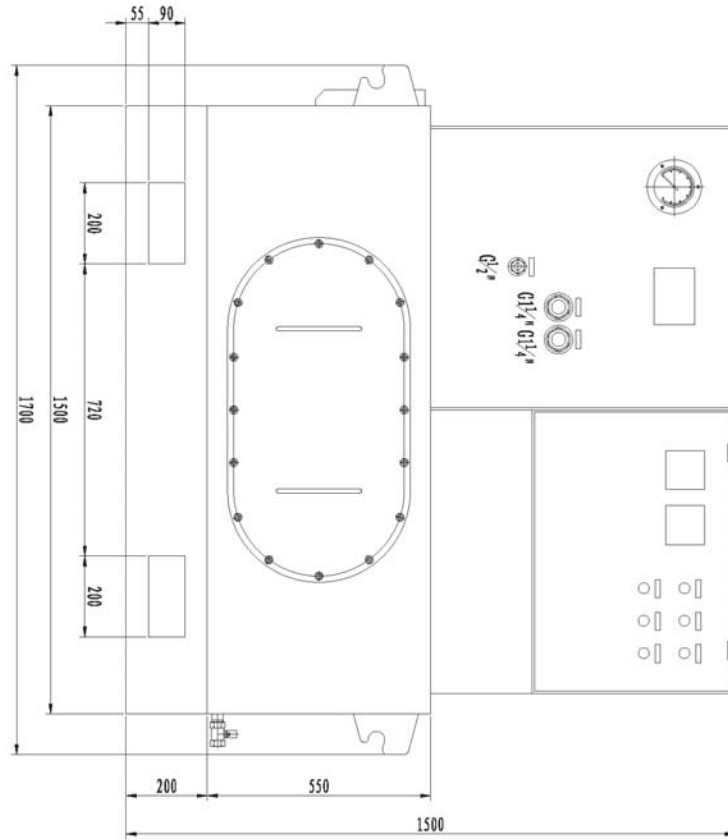

液压绞车 (1YJ5-100-55-25. 4-ZP) 配套液压泵站
 1YJ5-100-55-25. 4-ZP hydraulic winch power pack

Hydraulic Unit Figure

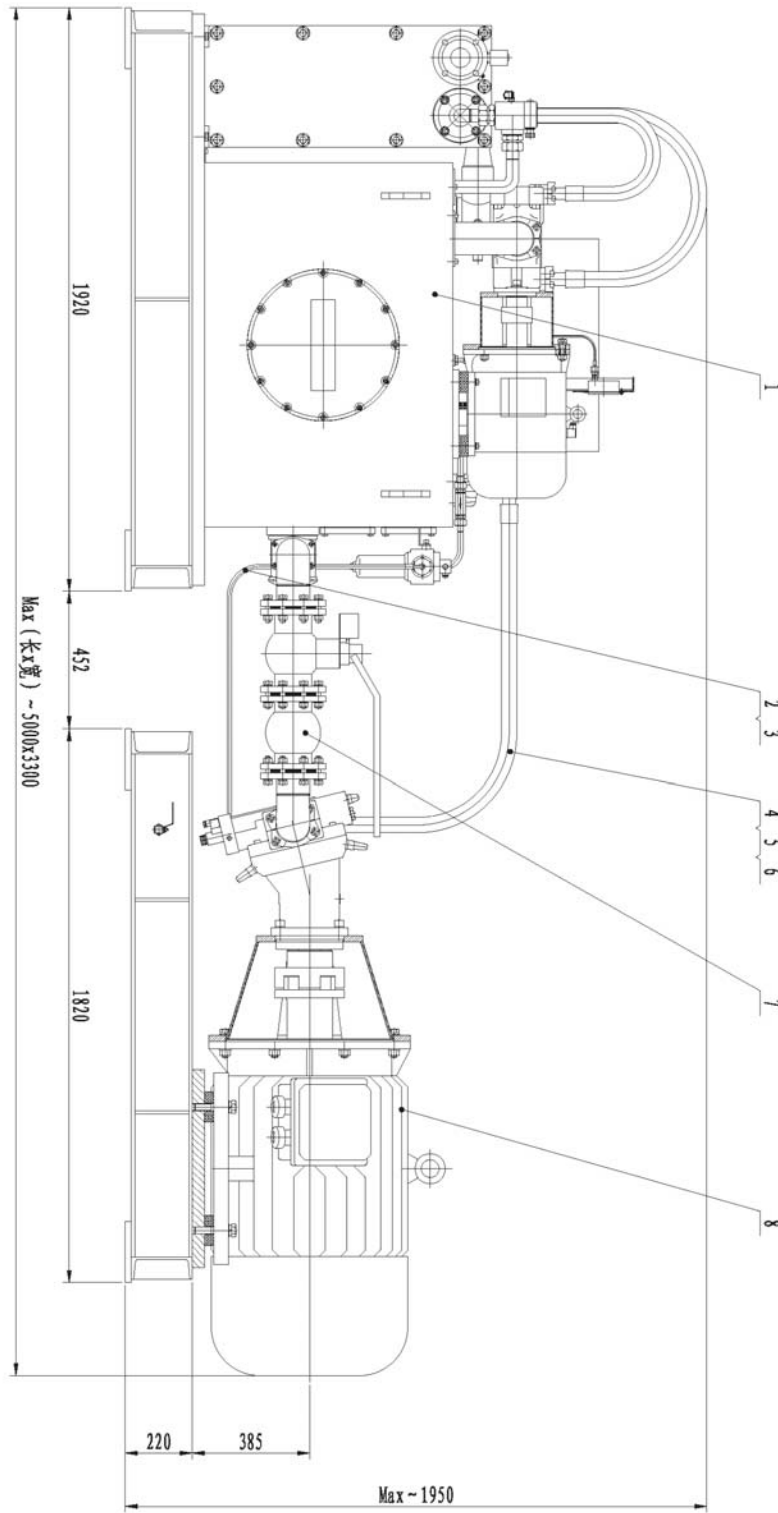

主泵站总图

Layout of main power pack

Hydraulic Unit Figure

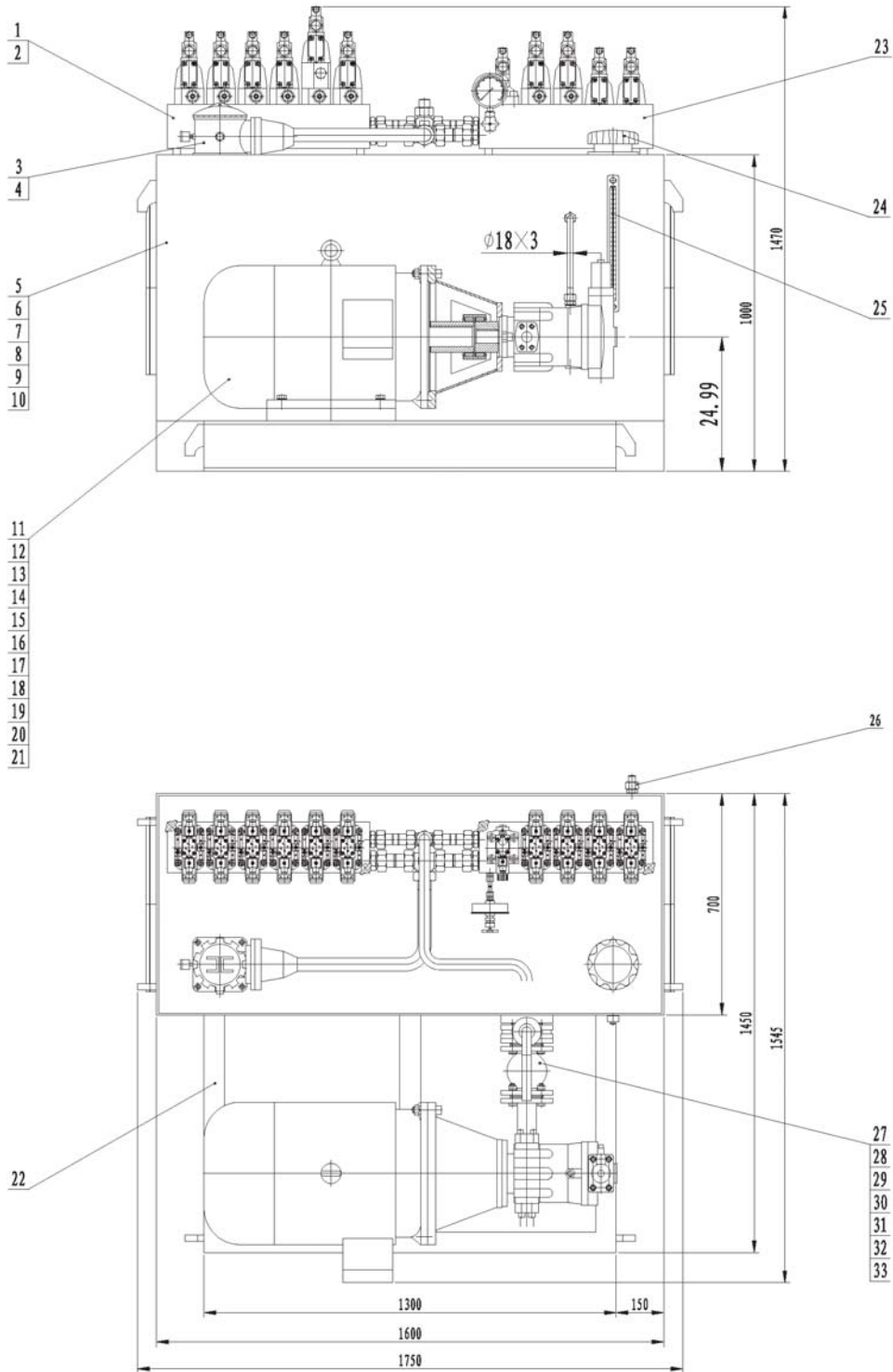

打桩机液压站总装图

Power pack for piling machines

Hydraulic Unit Figure

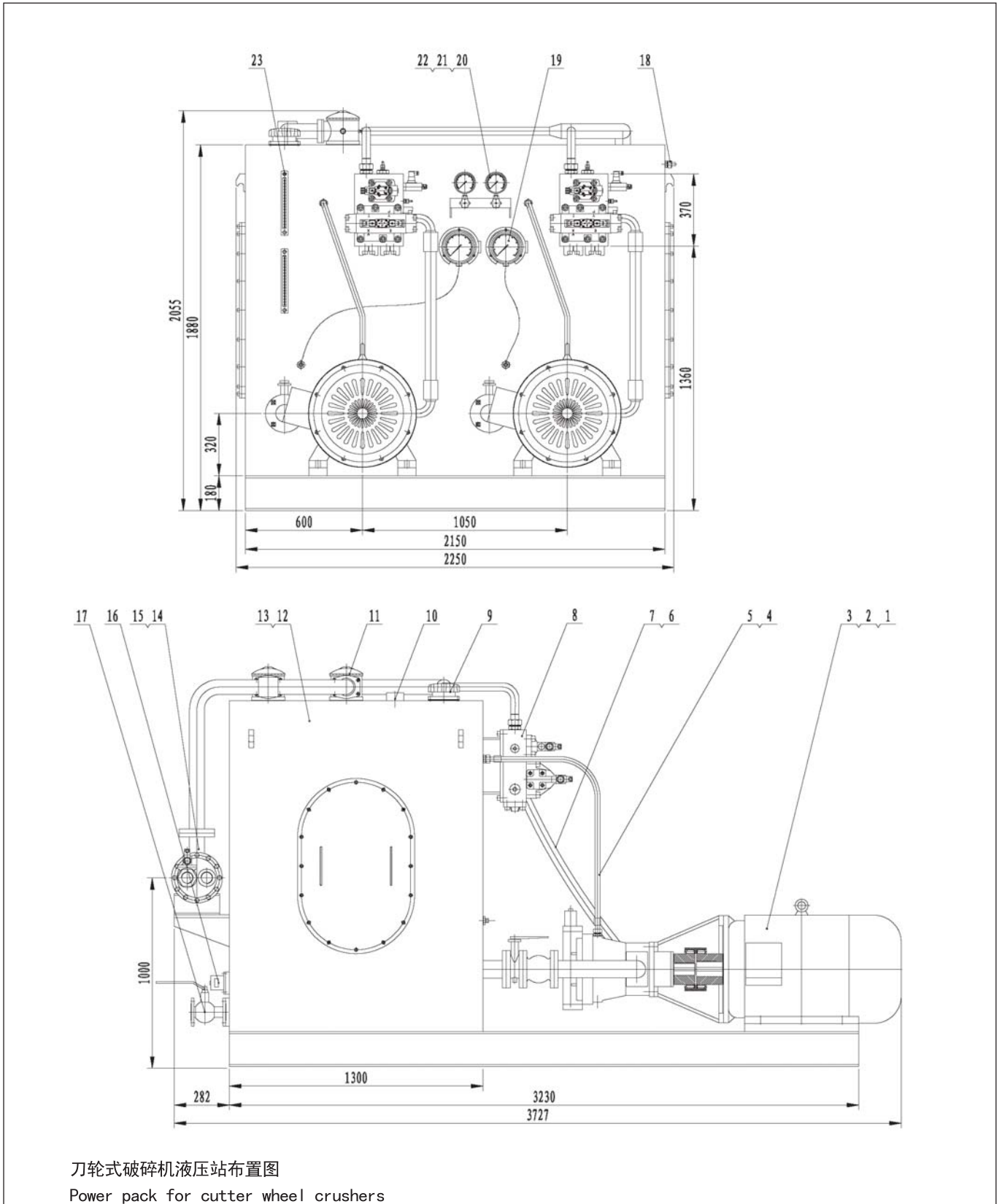

Hydraulic Unit Figure

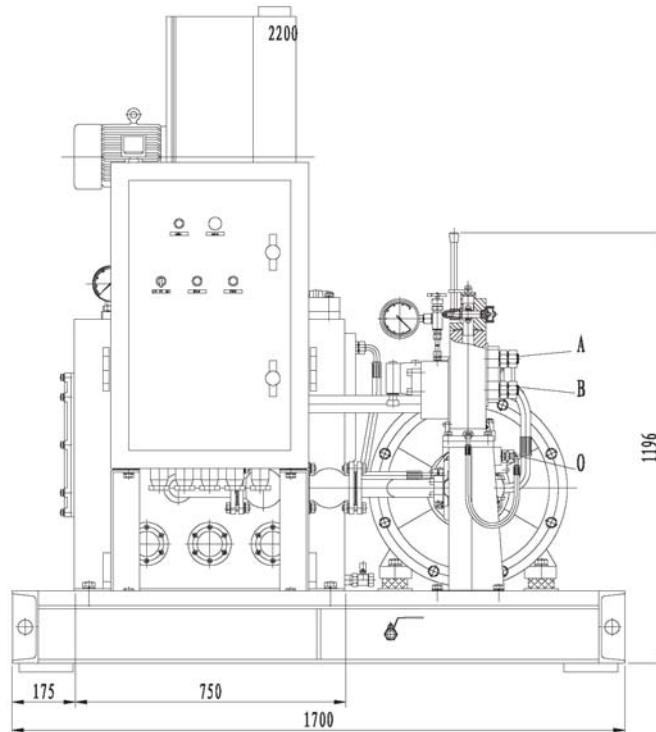
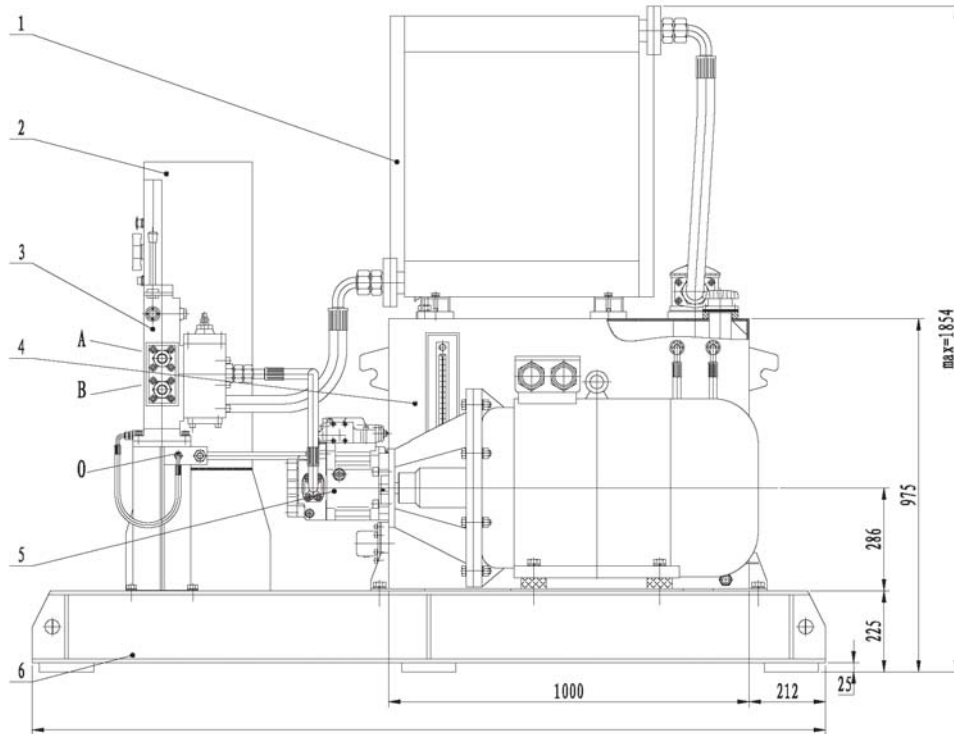

16T/18T 液压绞车配套泵站布置图

Power pack for 16T/18T hydraulic winches

Hydraulic Unit Figure

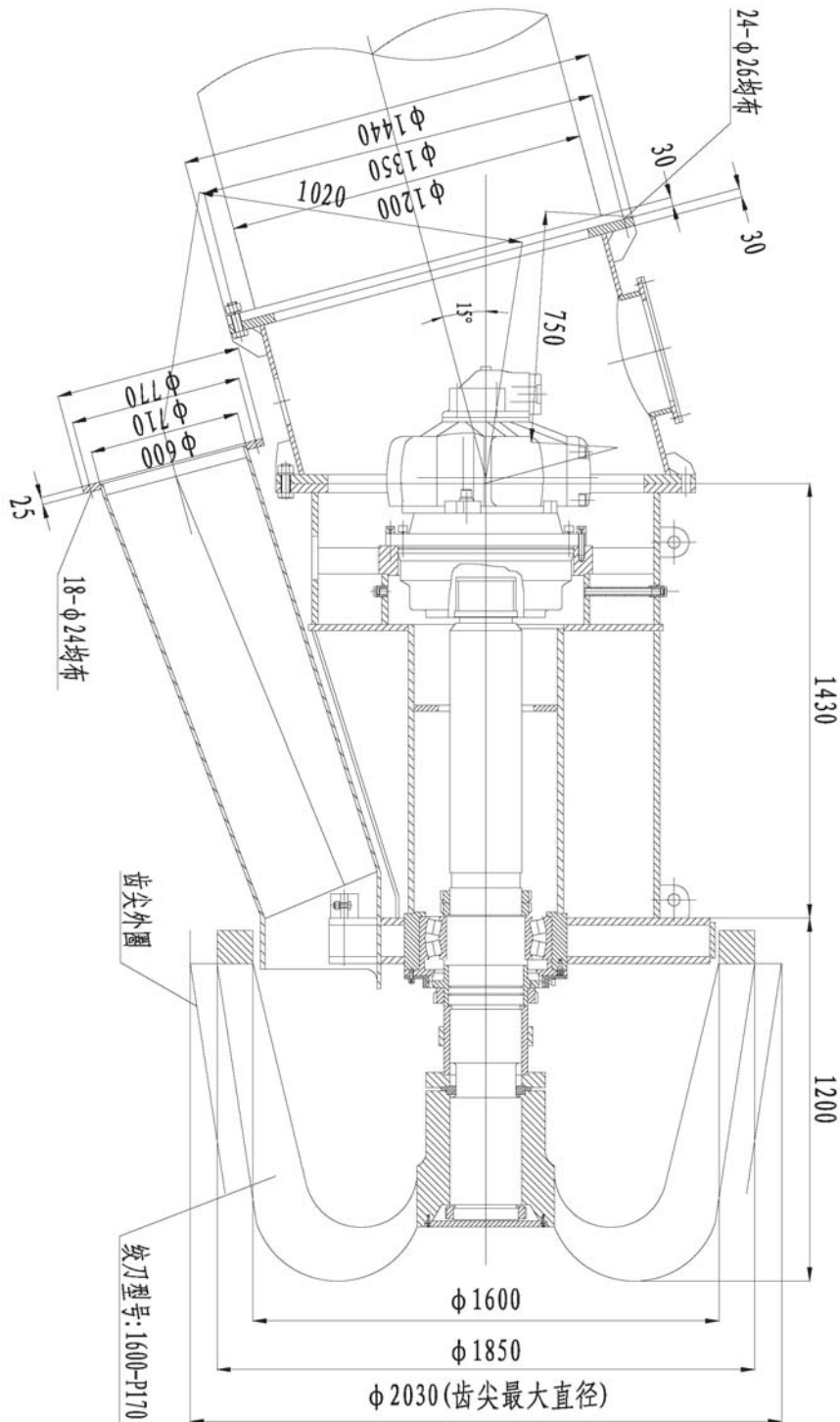

54KN.m 铰刀及传动装置外形安装图

54KN.m reamer and transmission erection diagram

Hydraulic Unit Figure

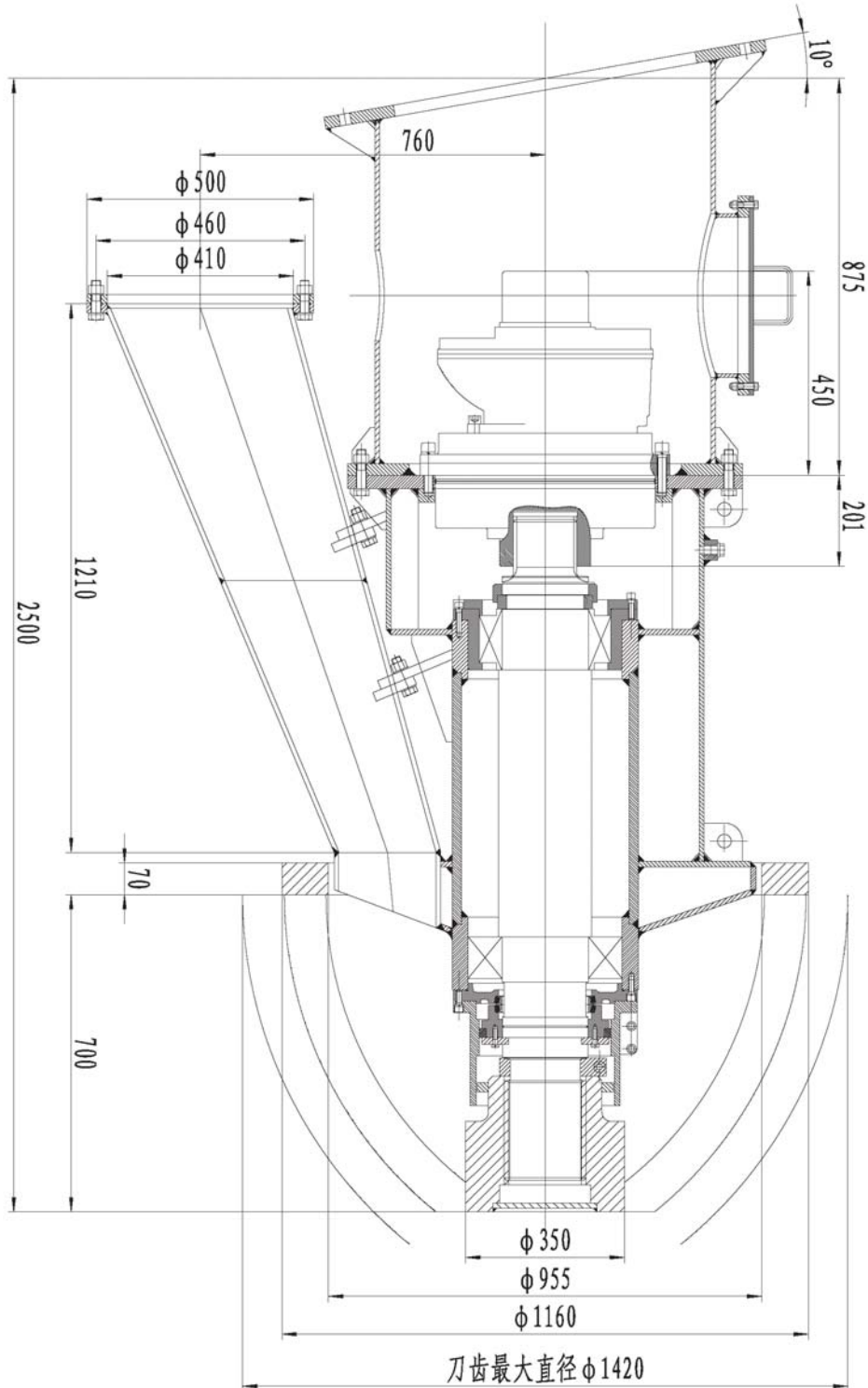

YJ型整体式液压铰刀装置

YJ type hydraulic reamer erection



意宁液压 INI HYDRAULIC

